



CSO Master Plan

Cockburn and Calrossie Districts Plan

August 2019

City of Winnipeg



CSO Master Plan

Project No: 470010CH
 Document Title: Cockburn and Calrossie Districts Plan
 Revision: 04
 Date: August 18, 2019
 Client Name: City of Winnipeg
 Project Manager: John Berry
 Author: Stephen Godon
 File Name: Cockburn_Plan_Final_CO1MP_08182019_Tracked

Jacobs Engineering Group Inc.

1301 Kenaston Boulevard
 Winnipeg, MB R3P 2P2
 Canada

www.jacobs.com

Limitation: This document has been prepared on behalf of, and for the exclusive use of Jacobs' client, and is subject to, and issued in accordance with, the provisions of the contract between Jacobs and the client. Jacobs accepts no liability or responsibility whatsoever for, or in respect of, any use of, or reliance upon, this document by any third party.

Document History and Status

Revision	Date	Description	By	Review	Approved
0	08/2018	DRAFT – Template Development	SG	ES	
1	11/2018	Version 1 DRAFT	SG	ES / JB / DT	
2	12/2018	Version 2 DRAFT	SG	ES / MF	
3	05/2019	Final Draft Submission	SG	MF	MF
4	08/18/2019	Final Submission For CSO Master Plan	MF	MF	SG

Contents

1.	Cockburn and Calrossie Districts	1
1.1	District Description	1
1.2	Development	1
1.3	Existing Sewer System	2
	1.3.1 District-to-District Interconnections	2
	1.3.2 Asset Information	4
1.4	Previous Investment Work	5
1.5	Ongoing Investment Work	6
1.6	Control Option 1 Projects	6
	1.6.1 Project Selection	6
	1.6.2 Sewer Separation.....	7
	1.6.3 In-line Storage.....	7
	1.6.4 Floatables Management	9
	1.6.5 Green Infrastructure.....	9
	1.6.6 Real Time Control	9
1.7	System Operations and Maintenance.....	10
1.8	Performance Estimate.....	10
1.9	Cost Estimates	11
1.10	Meeting Future Performance Targets	13
1.11	Risks and Opportunities	13
1.12	References.....	14

Tables

Table 1-1.	Sewer District Existing Asset Information.....	4
Table 1-2.	Critical Elevations	5
Table 1-3.	District Status.....	6
Table 1-4.	District Control Option.....	6
Table 1-5.	In-Line Storage Conceptual Design Criteria	8
Table 1-6.	Floatables Management Conceptual Design Criteria	9
Table 1-7.	InfoWorks CS District Model Data	10
Table 1-8.	District Performance Summary – Control Option 1	11
Table 1-9.	Cost Estimates – Control Option 1	11
Table 1-10.	Cost Estimate Tracking Table.....	12
Table 1-11.	Upgrade to 98 Percent Capture in a Representative Year Summary	13
Table 1-12.	Control Option 1 Significant Risks and Opportunities.....	14

Figure

Figure 1-1.	District Interconnection Schematic.....	3
-------------	---	---

1. Cockburn and Calrossie Districts

1.1 District Description

The Cockburn and Calrossie sewer districts are located at the southern limit of the combined sewer area. Cockburn is bounded by Grant Avenue on the north, Daly Street on the east, Jubilee and Parker Avenues on the south, and Cambridge Street on the west. Calrossie is a small separated sewer district located south of Jubilee Avenue between Pembina Highway and the Red River, extending south to Calrossie Boulevard. Figure 09 provides an overview of the sewer district and the location of the proposed Combined Sewer Overflow (CSO) Master Plan control options.

The Canadian National Railway (CNR) Mainline and CNR Letellier rail lines run through Cockburn and split it into two distinct parts; in terms of the combined sewer (CS) area, these are subsequently referred to as Cockburn East and Cockburn West. Cockburn East includes the Lord Roberts area, which developed as residential in the early 1900s, while the residential portion of Cockburn West was developed between the 1940s and 1960s.

Pembina Highway is a major regional roadway that runs parallel to the rail lines in a north-south direction; it intersects with Grant Avenue and Taylor Avenue, which are major regional streets that extend from Pembina Highway to the west.

Cockburn East is primarily residential, except for the railway corridor that originally contained the Fort Rouge Yards. The railway yards are in the process of being abandoned and replaced with the Southwest Rapid Transitway (SWRT), a new bus rapid transit roadway.

A portion of Cockburn West between Grant Avenue and Taylor Avenue is primarily residential, with single-family residential areas and multi-family apartment buildings along Grant and Taylor Avenues. Grant Avenue includes Grant Park shopping centre, Grant Park School, and Pan Am Pool. Taylor Avenue includes two commercial developments: Grant Park Pavilions and Grant Park Festival. Approximately 22 ha of the district is classified as greenspace, which includes multiple parcels spread throughout the district.

Calrossie is primarily a single-family residential area with some commercial properties along Pembina Highway.

1.2 Development

A significant level of development is ongoing within the Cockburn district. This includes the Fort Rouge Yards, the Taylor Lands, and the Parker Lands. Each of these areas have designated as Major Redevelopment Sites as part of the Complete Communities direction strategy within OurWinnipeg. The lands adjacent to the SWRT along the former Fort Rouge Yards are in the process of being developed into multi-family residential housing. The area south of Taylor Avenue and west of Pembina Highway is actively under development, as follows:

- The second phase of the SWRT is being constructed from the underpass at Pembina Highway and Jubilee Avenue in a westward direction parallel to Parker Avenue, before turning south to the University of Manitoba.
- Large commercial developments are taking place on the Taylor and Parker Lands. The Taylor Lands development has been zoned for commercial development and is proceeding. High-density residential development has been proposed for Parker Lands. Both development areas will be served by the new land drainage sewer (LDS) system, which is being installed as part of the basement flooding relief.
- The Pembina-Jubilee underpass is being widened to a six-lane underpass. The current design includes use of a dry pond to temporarily store stormwater with gradual release back into the CS system.

A portion of Pembina Highway is located within the Cockburn and Calrossie Districts. Pembina Highway is identified as Regional Mixed Use Corridor as part of the OurWinnipeg future development plans. As such, focused intensification along Pembina Highway is to be promoted in the future.

1.3 Existing Sewer System

The Cockburn district has an approximate area of 327¹ ha based on the district boundary. There is approximately 1 percent (4 ha) separated and no separation-ready areas. Separation work is ongoing with areas west and north of the rail line planned for LDS separation.

The Calrossie district has a drainage area of 16 ha and was originally a small CS district; it has since been completely separated through the addition of an LDS system. An LDS outfall is located in Toilers Memorial Park, near the intersection of Riverside Drive and Byng Place. In 2014, the LDS outfall was reconnected to the upstream side of the LDS gate chamber installed for the Cockburn West sewer separation project. The original CSs for Calrossie continue to discharge separate wastewater into the Cockburn CS system at the intersection of Jubilee Avenue and Riverside Drive.

The CS system includes a flood pump station (FPS), CS lift station (LS), one CS outfall, and one FPS outfall. All domestic wastewater and CS flows collected in Cockburn and Calrossie districts are routed to Cockburn Avenue, where the CS LS and outfall are located.

During dry weather flow (DWF), sewage flows are directed by the primary weir to the Cockburn CS LS and pumped to the Baltimore interceptor sewer. From Baltimore district, flows are pumped across the Red River to a gravity sewer flowing to the Mager CS LS. The Mager CS LS then pumps to the south end interceptor system, which flows by gravity to the South End Sewage Treatment Plant (SEWPCC). During wet weather flow (WWF), any flow that exceeds the diversion capacity of the primary weir is discharged into the Cockburn outfall, where it flows to the Red River by gravity. Sluice and flap gates are installed on the CS outfall to prevent back-up of the Red River into the CS system under high river level conditions.

Under these high river level conditions and when gravity discharge through the Cockburn CS outfall is not possible, the excess flow is pumped by the Cockburn FPS to a separate outfall adjacent to the CS outfall, where it will the discharge by gravity to the Red River. There are no sluice or flap gates on this FPS outfall.

The two CS outfalls to the Red River are as follows:

- ID1 (S-MA60012037) – Cockburn CS Outfall
- ID87 (S-MA60012037) – Cockburn FPS Outfall

1.3.1 District-to-District Interconnections

There are several sewer system interconnections between this district and the adjacent districts; see Figure 09. Interconnections include gravity and pumped flow from one district to the other. Each interconnection is listed in the following subsections:

1.3.1.1 Interceptor Connections – Downstream of Primary Weir

Baltimore

- The Cockburn CS LS discharges through a 250 mm force main into the Baltimore Interceptor, a gravity sewer beginning at Cockburn Street and Rosedale Avenue that flows through the Baltimore district to the Baltimore CS LS.

¹ City of Winnipeg GIS information relied upon for area statistics. The GIS records may vary slightly from the city representation in the InfoWorks sewer model. Therefore, minor discrepancies in the area values reported in Section 1.3 Existing Sewer System, and in Section 1.8 Performance Estimate may occur.

1.3.1.2 District Interconnections**Calrossie**WWS to CS

- A 200 mm WWS pipe from Calrossie flows into the Cockburn CS system at the intersection of Jubilee Avenue and Riverside Drive. (S-MH60010185)

JessieCS to CS

- High Point Manhole (flow is directed into both districts from this manhole)
 - Ebby Avenue and Wentworth Street – 228.93 m (S-MH60010140)
- A 300 mm CS sewer acts as an overflow pipe from the Cockburn CS system into the Jessie CS system.
 - Jackson Avenue and Stafford Avenue – 229.29 m (S-MH60010066)

LDS to LDS

- A 1350 mm LDS trunk conveys flow from the Fort Rouge Yards development area within Cockburn to an LDS outfall discharging to the Red River and located in the Jessie sewer district.

BaltimoreCS to CS

- High Point Manholes (flow is directed into both districts from these manholes)
 - Montague Avenue and Nassau Street South – 228.83 m (S-MH60010528)
 - McNaughton Avenue and Nassau Street South – 228.82 m (S-MH60010544)
 - Churchill Drive – 229.71 m (S-MH60010728)

A district interconnection schematic is included as Figure 1-1. The drawing illustrates the collection areas, interconnections, pumping systems, and discharge points for the existing district.

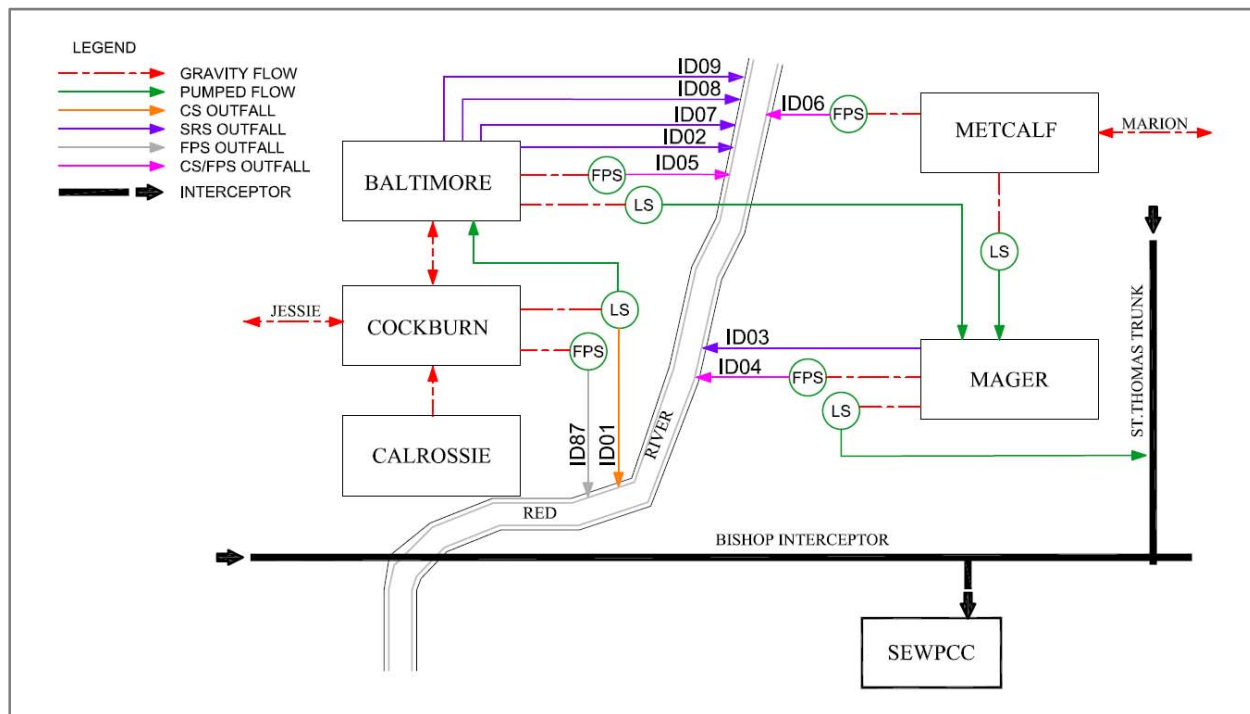

Figure 1-1. District Interconnection Schematic

1.3.2 Asset Information

The main sewer system features for the district are shown on Figure 09 and are listed in Table 1-1.

Table 1-1. Sewer District Existing Asset Information

Asset	Asset ID (Model)	Asset ID (GIS)	Characteristics	Comments
Combined Sewer Outfall (ID1)	S-CS00000475 DS.1	S-MA60012037	1675 mm	Red River Invert: 222.66 m
Flood Pumping Outfall (ID87)	S-TE70028256.1	S-MA60012037	1524 mm	Red River Invert: 221.93 m
Other Overflows	N/A	N/A	N/A	
Main Sewer Trunk	N/A	S-MA60012153	2800 x 2100 mm	Invert: 223.07 m
Storm Relief Sewer Outfalls	N/A	N/A	N/A	
Storm Relief Sewer Interconnections	N/A	N/A	N/A	
Main Trunk Flap Gate	S-CS00000475.1	S-CG00000764	2000 mm	Invert: 223.21 m
Main Trunk Sluice Gate	S-CG00000765.1	S-CG00000765	1810 mm	Invert: 223.03 m
Off-Take	S-TE70008629.2	S-MA70018505	406 mm	Invert 223.00 m
Wet Well	S-MH70006766.1	S-MA70018509	14 m x 2.3 m	
Lift Station Total Capacity	N/A	N/A	0.098 m ³ /s	1 x 0.035 m ³ /s 1 x 0.063 m ³ /s pumps
Lift Station ADWF	N/A	N/A	0.017 m ³ /s	
Lift Station Force Main	S-BE70003227.1	S-MA70018509	250 mm	Discharge Invert 230.10

Table 1-1. Sewer District Existing Asset Information

Asset	Asset ID (Model)	Asset ID (GIS)	Characteristics	Comments
				m
Flood Pump Station Total Capacity	N/A	N/A	2.380 m ³ /s	3 pumps at 0.851 m ³ /s
Pass Forward Flow – First Overflow	N/A	N/A	0.052 m ³ /s	

Notes:

ADWF = average dry-weather flow
 GIS = geographic information system
 ID = identification
 N/A = not applicable

The critical system elevations for the existing system relevant to the development of the CSO control options are listed in Table 1-2. Critical elevation reference points are identified on the district overview and detailed maps.

Table 1-2. Critical Elevations

Reference Point	Item	Elevation (m) ^a
1	Normal Summer River Level	223.75
2	Trunk Invert at Off-Take	223.00
3	Top of Weir	223.38
4	Relief Outfall Invert at Flap Gate	N/A
5	Low Relief Interconnection	N/A
6	Sewer District Low Interconnection (Baltimore)	228.28
7	Low Basement	229.73
8	Flood Protection Level	230.16

^a City of Winnipeg Data, 2013

1.4 Previous Investment Work

Calrossie district was completely separated in 2010. The work included construction of a new LDS with reconnection of the catch basins to collect all road drainage and surface runoff. The original CS now serves as a WWS, with collection of foundation drainage and any flows from downspouts that may still be connected to the separate system.

A basement flooding relief (BFR) preliminary design report (KGS, 2015) was completed for Cockburn and the southeastern portion of the Jessie sewer district in 2015. Separation of a portion of the Jessie sewer district is included with Cockburn BFR, with separated stormwater collected through Cockburn West and the sanitary system continuing to be collected by Jessie district through the original CSs. Southeast Jessie relief was not included when the rest of the Jessie district was relieved in the 1970s and was added to the Cockburn district relief study because of proximity.

The study included creation of a drainage hydraulic model, flow monitoring for model calibration, and evaluation of BFR alternatives and associated cost estimates. Work to date has included a LDS trunk across the CNR, a stormwater retention basin on Parker Lands, and a land drainage trunk to the outfall at Toilers Memorial Park into the Red River. Table 1-3 provides a summary of the district status in terms of data capture and study.

Between 2009 and 2015, the City invested \$12 million in the CSO Outfall Monitoring Program. The program was initiated to permanently install instruments in the primary CSO outfalls. The outfall from the

Cockburn district was included as part of this program. Instruments installed at each of the 39 primary CSO outfall locations have a combination of inflow and overflow level meters and flap gate inclinometers, if available.

Table 1-3. District Status

District	Most Recent Study	Flow Monitoring	Hydraulic Model	Status	Expected Completion
Cockburn	2015 – Preliminary Design	Yes	2013	Under Construction	TBD
Calrossie	N/A	No	2013	Separation Complete	N/A
Southeast Jessie	2015 – Preliminary Design	Yes	2013	Under Construction	TBD

Note:
TBD = to be determined

1.5 Ongoing Investment Work

The Cockburn BFR program work began in 2013 with construction of a new LDS outfall and trunk sewer. Once completed, the LDS system will provide complete road drainage separation of Cockburn West and southeast Jessie.

There is ongoing maintenance and calibration of permanent instruments installed within the primary outfall within the Cockburn district. This consists of monthly site visits in confined entry spaces to verify that physical readings concur with displayed transmitted readings and replacing desiccants where necessary.

1.6 Control Option 1 Projects

1.6.1 Project Selection

The proposed projects selected to meet Control Option 1 – 85 Percent Capture in a Representative Year for the Cockburn sewer district are listed in Table 1-4. The proposed CSO control projects will include sewer separation, in-line storage with screening, and floatable management. Program opportunities including green infrastructure (GI) and real time control (RTC) will also be included as applicable.

Table 1-4. District Control Option

Control Limit	Latent Storage	Flap Gate Control	Gravity Flow Control	Control Gate	In-line Storage	Off-line Storage Tank	Off-line Storage Tunnel	Sewer Separation	Green Infrastructure	Real Time Control	Floatable Management
85 Percent Capture in a Representative Year	-	-	-	✓	✓	-	-	✓	✓	✓	✓

Notes:
- = not included
✓ = included

The Cockburn sewer district is identified as a priority, because it was previously identified as needing basement flooding relief. The BFR program was well underway at the time of the CSO Master Plan

development, and a decision had been previously made to separate Cockburn West, while deferring Cockburn East until more information became available under the CSO Master Plan.

The marginal evaluation indicated that in-line storage for Cockburn East will be more economical than continuing with full separation of the district and will provide a high level of CSO control. In-line storage is lower in cost and will be effective because of the reduced inflows resulting from partial separation and the subsequent large volume of storage available in the existing CS.

All primary overflow locations are to be screened under the current CSO control plan. Installation of a control gate will be required for the screen operation, and it will provide the mechanism for capture of the in-line storage.

Floatable control will be necessary to capture floatables in the sewage. Floatables will be captured with all implemented control options to some extent, but screening may be added as required to reach the desired level of capture.

GI and RTC will be applied within each district on a system-wide basis with consideration of the entire CS area. The level of implementation for each district will be determined through evaluations completed through district level preliminary design.

1.6.2 Sewer Separation

The sewer separation project for Cockburn West will provide immediate benefits to the CSO program when complete. The work includes installation of an independent LDS system to collect road drainage. Collected stormwater runoff will be routed through a new stormwater retention pond to an outfall discharging to the Red River at Toilers Memorial Park, located in the Calrossie sewer district. The approximate area of sewer separation is shown on Figure 09.

The flows to be collected after Cockburn West separation will be as follows:

- DWF will remain the same for Cockburn district (and for southeast Jessie).
- Cockburn West WWF will consist of sanitary sewage combined with foundation drainage.
- Cockburn East will remain as combined sewage.

This will result in a significant reduction in combined sewage flow received at Cockburn CS LS after the separation project is complete. The separation project by itself will provide a partial reduction of overflows and must be accompanied by in-line storage at the Cockburn diversion.

In addition to BFR and reducing the CSO volume, the benefits of Cockburn West separation include making storage volume available in the CS system for in-line storage and reducing the amount of flood pumping required at the Cockburn FPS.

1.6.3 In-line Storage

In-line storage has been proposed as a CSO control for Cockburn district. The in-line storage will require the installation of a control gate at the CS outfall. The gate will increase the storage level in the existing CS to provide an overall higher volume capture and will provide additional hydraulic head for screening operations.

A standard design was assumed for the control gate, as described in Part 3C. A standard approach was used for conceptual gate sizing by assuming it to be the lesser of the height of half of the site-specific trunk diameter or the maximum height of the gate available. The design criteria for in-line storage are listed in Table 1-5.

Table 1-5. In-Line Storage Conceptual Design Criteria

Item	Elevation/Dimension	Comment
Invert Elevation	223.07 m	
Trunk Height	2700 x 2075 mm	
Gate Height	1.35 m	Based on half pipe height
Top of Gate Elevation	224.42 m	
Bypass Weir Height	224.32 m	
Maximum Storage Volume	2,600 m ³	
Nominal Dewatering Rate	0.098 m ³ /s	Based on existing CS LS capacity
RTC Operational Rate	TBD	Future RTC / dewatering review on performance

The proposed control gate will cause combined sewage to back-up in the collection system to the extent shown on Figure 09. The extent of the in-line storage and volume is related to the top elevation of the bypass side weir. The level of the bypass side weir and adjacent control gate level area determined in relation to the critical performance levels in the system for basement flooding protection: when the system level increases above the bypass weir crest and proceeds above the top of the control gate during high flow events, the control gate drops out of the way. At this point, the district will only provide its original interception capacity via the primary weir for the district, and all excess CS would flow over the weir and discharge to the river. After the sewer levels in the system drops back below the bypass side weir critical performance level, the control gate moves back to its original position to capture the receding limb of the WWF event. The CS LS will continue with its current operation while the control gate is in either position, with all DWF being diverted to the CS LS and pumped. The CS LS will further dewater the in-line storage provided during a WWF event as downstream capacity becomes available.

Figure 09-01 provides an overview of the conceptual location and configuration of the control gate, bypass weir, and screening chambers. The proposed control gate will be installed in a new chamber within the existing trunk sewer alignment near the existing CS LS and FPS. The dimensions of the chamber will be 6 m in length and 3.5 m in width to accommodate the gate, with an allowance for a longitudinal overflow weir. The existing sewer configuration including the off-take, the 900 mm CS sewer along Churchill Drive, and the force main may have to be modified to accommodate the new chamber. Further optimization of the gate chamber size may be provided if a decision is made not to include screening.

The physical requirements for the off-take and station sizing for a modification to pumping capacity have not been considered in detail, but they will be required in the future as part of an RTC program or LS rehabilitation or replacement project.

The nominal rate for dewatering is set at the existing CS LS station capacity. The dewatering rate includes both the DWF and WWF components of the district flows. This allows dewatering through the existing interceptor system within 24 hours following the runoff event, allowing it to recover in time for a subsequent event. Any future considerations, for RTC improvements, would be completed with spatial rainfall as any reduction to the existing capacity for large events will adversely affect the overflows at this district. . This future RTC will provide the ability to capture and treat more volume for localized storms by using either the district in-line storage or the excess interceptor capacity where the runoff volume is less. Further assessment of the impact of the RTC and future dewatering arrangement will be necessary to review the impacts on downstream districts such as the Baltimore and Mager districts.

1.6.4 Floatables Management

Floatables management will require installation of a screening system to capture floatable materials. The off-line screens will be proposed to maintain the current level of basement flooding protection.

The type and size of screens depend on the specific station configuration and the hydraulic head available for operation. A standard design was assumed for screening and is described in Part 3C. The design criteria for screening, with an in-line control gate implemented, are listed in Table 1-6.

Table 1-6. Floatables Management Conceptual Design Criteria

Item	Elevation/Dimension/Rate	Comment
Top of Gate	224.55 m	
Bypass Weir Crest	224.40 m	
Normal Summer River Level	223.75 m	
Maximum Screen Head	0.65 m	
Peak Screening Rate	0.52 m ³ /s	
Screening Size	1.5 m wide x 1 m high	Modelled Screen Size

The proposed side bypass overflow weir and screening chamber will be located adjacent to the proposed control gate and existing CS trunk, as shown on Figure 09-01. The screens will operate with the control gate in the raised position, diverting flows to the bypass weir. A side bypass weir upstream of the gate will direct the flow to the screens located in the new screening chamber, with screened flow discharged to the downstream side of the gate to the river. The screening chamber will include screenings pumps with a discharge returning the screened material to the CS LS for routing to the SEWPCC for removal.

The dimensions for the screen chamber to accommodate influent from the side weir, the screen area, and the routing of the discharge piping downstream of the gate are 4 m in length and 3 m in width. The existing sewer configuration including the off-take, the 900 mm CS sewer along Churchill Drive, and the LS force main may have to be modified to accommodate the new chamber.

1.6.5 Green Infrastructure

The approach to GI is described in Section 5.2.1 of Part 2 of the CSO Master Plan. Opportunities for the application of GI will be evaluated and applied with any projects completed in the district. Opportunistic GI will be evaluated for the entire district during any preliminary design completed. The land use, topography and soil classification for the district will be reviewed to identify the most applicable GI controls.

Cockburn has been classified as a high GI potential district. A portion of Cockburn West between Grant Avenue and Taylor Avenue is primarily residential, with single-family residential areas and multi-family apartment buildings along Grant and Taylor Avenues. This means the district would be an ideal location for bioswales, permeable paved roadways, cisterns/rain barrels, and rain gardens. The higher area of greenspace in Cockburn district is suitable for biorientation garden projects. The commercial buildings along Taylor Avenue, Grant Avenue, and Pembina Highway are ideal locations for green roof projects.

1.6.6 Real Time Control

The approach to RTC is described in Section 5.2.2 of Part 2 of the CSO Master Plan. The application of RTC will be evaluated and applied on a district by district basis through the CSO Master Plan projects with long term consideration for implementation on a system wide basis.

1.7 System Operations and Maintenance

System operations and maintenance (O&M) changes will be required to address the proposed control options. This section identifies general O&M requirements for each control option proposed for the district. More specific details on the assumptions used for quantifying the O&M requirements are described in Part 3C of the CSO Master Plan.

Sewer separation will include the installation of additional sewers that will require inspection, cleaning and rehabilitation. This will result in additional maintenance costs over the long term, but operational costs will be minimal. The existing larger CS pipes within the district may also receive insufficient flows with the separation work for proper scouring velocities in the sewer pipes. This could result in solids settling within the sewers and requiring more frequent cleaning operations. However, the WWF flows from the non-separated east Cockburn area will offset part of this concern. The impacts of the reduced flows in larger CS pipes will be evaluated as part of the sewer separation design for the district. The stormwater retention pond and LDS gate chamber at Toilers Memorial Park are included as part of routine LDS operation.

In-line storage will impact the existing sewer and will require the addition of a new chamber and a moving gate at the outfall. In-line storage dewatering will be controlled with the existing Cockburn LS, which will require more frequent and longer duration pump run times. Lower velocities will occur in the CS trunk in the vicinity of the control gate due to lower pass forward flows, and may create additional debris deposition requiring cleaning. Additional system monitoring, and level controls will be installed, which will require regular scheduled maintenance. However, the sewer separation will remove storm runoff flows that will lower the duration and frequency of the pump run times.

Floatable control with outfall screening will require the addition of another chamber with screening equipment installed. The chamber will be installed adjacent to the control gate chamber and will operate in conjunction with it. Screening operation will occur during WWF events that surpass the in-line storage control level. WWF will be directed from the main CS trunk, over the side weir in the control gate chamber and through the screens to discharge into the river. The screens will operate intermittently during wet weather events and will likely require operations review and maintenance after each event. The frequency of a screened event will correlate to the number overflows identified for the district. Having the screenings pumped back to the interceptor system via a small LS and force main will be required. Additional maintenance for the pumps will be required at regular intervals in line with typical lift station maintenance and after significant screening events.

1.8 Performance Estimate

An InfoWorks CS hydraulic model was created as part of the CSO Master Plan development. An individual model was created to represent the sewer system baseline as represented in the year 2013 and a second model was created for the CSO Master Plan evaluation purposes, with all the control options recommended for the district to meet Control Option 1 implemented in the year 2037. A summary of relevant model data is provided in Table 1-7.

Table 1-7. InfoWorks CS District Model Data

Model Version	Total Area (ha)	Contributing Area (ha)	Population	% Impervious	Control Options Included in Model
2013 Baseline	336	336	5,584	27	N/A
2037 Master Plan – Control Option 1	323	312	5,584	19	SEP, IS, SC

Notes:

SEP = Separation
 IS = In-line Storage
 SC = Screening

No change to the future population was completed as from a wastewater generation perspective from the update to the 2013 Baseline Model to the 2037 Master Plan Model. The population generating all future wastewater will be the same due to Clause 8 of

Table 1-7. InfoWorks CS District Model Data

Model Version	Total Area (ha)	Contributing Area (ha)	Population	% Impervious	Control Options Included in Model
---------------	-----------------	------------------------	------------	--------------	-----------------------------------

Environment Act Licence 3042 being in effect for the CS district.

City of Winnipeg hydraulic model relied upon for area statistics. The hydraulic model representation may vary slightly from the City of Winnipeg GIS Records. Therefore minor discrepancies in the area values reported in Section 1.3 Existing Sewer System, and in Section 1.8 Performance Estimate may occur.

The performance results listed in Table 1-8 are for the hydraulic model simulations using the year-round 1992 representative year. The table lists the results for the Baseline, for each individual control option, and for the proposed CSO Master Plan - Control Option 1. The Baseline and Control Option 1 performance numbers represent the comparison between the existing system and the proposed control options. Table 1-8 also includes overflow volumes specific to each individual control option; these are listed to provide an indication of benefit gained only and are independent volume reductions.

Table 1-8. District Performance Summary – Control Option 1

Control Option	Preliminary Proposal	Master Plan			
	Annual Overflow Volume (m ³)	Annual Overflow Volume (m ³)	Overflow Reduction (m ³)	Number of Overflows	Pass Forward Flow at First Overflow ^b
Baseline (2013)	164,713	188,459	0	22	0.075 m ³ /s
Cockburn West Separation	12,297 ^a	14,541	173,918	15	0.087 m ³ /s
In-Line Storage + Cockburn West Separation		6,183	182,276	4	0.126 m ³ /s
Control Option 1	12,297	6,183	182,276	4	0.126 m³/s

^a Separation and In-line Storage were not simulated independently during the Preliminary Proposal assessment

^b Pass forward flows assessed on the 1-year design rainfall event.

The percent capture performance measure is not included in Table 1-8 above, as it is applicable to the entire CS system and not for each district individually.

1.9 Cost Estimates

Cost estimates were prepared during the development of the Preliminary Proposal and have been updated for the CSO Master Plan. The CSO Master Plan cost estimates have been prepared for each control option, with overall program costs summarized and described in Section 3.4 of Part 3A. The cost estimate for each control option relevant to the district as determined in the Preliminary Proposal and updated for the CSO Master Plan are identified in Table 1-9. The cost estimates are a Class 5 planning level estimates with a level of accuracy of minus 50 percent to plus 100 percent.

Table 1-9. Cost Estimates – Control Option 1

Control Option	2014 Preliminary Proposal Capital Cost	2019 CSO Master Plan Capital Cost	2019 Annual Operations and Maintenance Cost	2019 Total Operations and Maintenance (Over 35-year period)
Sewer Separation	\$89,370,000 ^a	\$56,280,000 ^c	\$30,000	\$720,000
In-line Storage	N/A ^b	\$2,650,000	\$40,000	\$890,000
Screening		\$2,250,000 ^d	\$30,000	\$730,000

Subtotal	\$89,370,000	\$61,180,000	\$110,000	\$2,340,000
Opportunities	N/A	\$6,120,000	\$10,000	\$230,000
District Total	\$89,370,000	\$67,300,000	\$120,000	\$2,570,000

^a Solution development as refinement to Preliminary Proposal costs. Revised cost for this sewer separation work found to be \$47,490,000 in 2014 dollars

^b Solution development as refinement to Preliminary Proposal costs. Revised costs for these items of work found to be \$4,400,000 in 2014 dollars

^c Cockburn separation is approximately 20% complete and at the time of CSO Master Plan development. An adjustment to the total capital cost estimate has been included in the Master Plan cost to account for this

^d Cost for bespoke screenings return pump/force main not included in Master Plan as will depend on selection of screen and type of screening return system selected

The estimates include changes to the control option selection since the Preliminary Proposal, updated construction costs, and the addition of GI opportunities. The calculations for the CSO Master Plan cost estimate includes the following:

- Capital costs and O&M costs are reported in terms of present value.
- A fixed allowance of 10 percent has been included for GI, with no additional cost for RTC.
- The Preliminary Proposal capital cost is in 2014 dollar values.
- The CSO Master Plan capital cost is based on the control options presented in this plan and in 2019 dollar values.
- The 2019 Total Annual Operations and Maintenance (over 35-year period) cost component is the present value costs of each annual O&M cost under the assumption that each control option was initiated in 2019. Each of these values include equipment replacement and O&M costs.
- The 2019 Annual Operations and Maintenance Costs were based on the estimated additional O&M costs annually for each control option in 2019 dollars.
- Future costs will be inflated to the year of construction.

Cost estimates were prepared during the development of the Preliminary Proposal and updated for Phase 3 during the CSO Master plan development. The differences identified between the Preliminary Proposal and the CSO Master Plan are accounting for the progression from an initial estimate used to compare a series of alternative plans for the entire system, to an estimate focusing on a specific level of control for each district. Any significant differences between the Preliminary Proposal and CSO Master Plan estimates are identified in Table 1-10.

Table 1-10. Cost Estimate Tracking Table

Changed Item	Change	Reason	Comments
Control Options	Separation	Unit costs were updated Cockburn West area removed from estimate. The percent separation was adjusted to account for construction completed.	
	In-line Storage	A control gate was not included in the Preliminary Proposal estimate	Added for the Master Plan to further reduce overflows
	Screening	Screening was not included in the Preliminary Proposal estimate	Added in conjunction with the Control Gate
Opportunities	A fixed allowance of 10 percent has been included for program opportunities	Preliminary Proposal estimate did not include a cost for GI opportunities	
Lifecycle Cost	The lifecycle costs have been	City of Winnipeg Asset	

	adjusted to 35 years	Management approach	
Cost escalation from 2014 to 2019	Capital Costs have been inflated to 2019 values based on an assumed value of 3 percent per for construction inflation.	Preliminary Proposal estimates were based on 2014-dollar values.	

1.10 Meeting Future Performance Targets

The regulatory process requires consideration for upgrading Control Option 1 to another higher-level performance target. For the purposes of this CSO Master Plan, the future performance target is 98 percent capture for the representative year measured on a system-wide basis. This target will permit the number of overflows and percent capture to vary by district to meet 98 percent capture. Table 1-11 provides a description of how the regulatory target adjustment could be met by building off the proposed work identified for Control Option 1.

Overall the Cockburn district would be classified as a high potential for implementation of complete sewer separation as the feasible approach to achieve the 98 percent capture in the representative year future performance target. The non-separation measures recommended as part of this district engineering plan to meet Control Option 1, specifically in-line storage and floatables management via off-line screening, are therefore at risk of becoming redundant and unnecessary when the measures to achieve future performance targets are pursued. As a result, these measures should not be pursued until the requirements to meet future performance targets are more defined. Should it be confirmed that complete separation is the recommended solution to meet future performance targets, then complete separation will likely be pursued to address Control Option 1 instead of implementing the non-separation measures. This will be with the understanding that while initial complete separation is less cost-effective to meet Control Option 1, it is the most cost effective solution to meet the future performance target and removes the capital costs on short term temporary solutions. Focused use of green infrastructure, and reliance on said green infrastructure as well can provide volume capture benefits and could be utilized to meet future performance targets.

Table 1-11. Upgrade to 98 Percent Capture in a Representative Year Summary

Upgrade Option	Viable Migration Options
98 Percent Capture in a Representative Year	<ul style="list-style-type: none"> Separation of remainder of Cockburn district Increased use of GI

The control options selected for the Cockburn district has been aligned with the City’s committed projects for the BFR program. The expandability of this district to meet the 98 percent capture would be based on a system wide assessment. The cost for upgrading to meet an enhanced performance target depends on the summation of all changes made to control options in individual districts and has not been fully estimated at this stage of master planning. The Phase In approach is to be presented in detail in a second submission for 98 percent capture in a representative year, due on or before April 30, 2030.

1.11 Risks and Opportunities

The CSO Master Plan and implementation program are large and complex, with many risks having both negative and positive effects. The objective of this section is to identify significant risks and opportunities for each control option within a district.

The CSO Master Plan has considered risks and opportunities on a program and project delivery level, as described in Section 5 of Part 2 of the CSO Master Plan. A Risk And Opportunity Control Option Matrix covering the district control options has been developed and is included as Appendix D in Part 3B. The

identification of the most significant risks and opportunities relevant to this district are provided in Table 1-12.

Table 1-12. Control Option 1 Significant Risks and Opportunities

ID Number	Component	Latent Storage / Flap Gate Control	In-line Storage / Control Gate	Off-line Storage Tank	Off-line Storage Tunnel	Sewer Separation	Green Infrastructure	Real Time Control	Floatable Management
1	Basement Flooding Protection	-	R	-	-	O	-	-	-
2	Existing Lift Station	-	R	-	-	-	-	R	-
3	Flood Pumping Station	-	-	-	-	O	-	-	-
4	Construction Disruption	-	-	-	-	R	-	-	-
5	Implementation Schedule	-	-	-	-	R	-	R	-
6	Sewer Condition	-	R	-	-	-	-	-	-
7	Sewer Conflicts	-	R	-	-	R	-	-	-
8	Program Cost	-	R/O	-	-	R	-	-	O
9	Approvals and Permits	-	-	-	-	-	R	-	-
10	Land Acquisition	-	-	-	-	-	R	-	-
11	Technology Assumptions	-	-	-	-	O	O	O	-
12	Operations and Maintenance	-	R	-	-	R / O	R	O	R
13	Volume Capture Performance	-	O	-	-	-	O	O	-
14	Treatment	-	R	-	-	O	O	O	R

Risks and opportunities will require further review and actions at the time of project implementation.

1.12 References

KGS Group. 2015. *Cockburn and Calrossie Combined Sewer Relief Works Preliminary Design Report*. Prepared for the City of Winnipeg, Waterworks, Waster and Disposal Department. June.

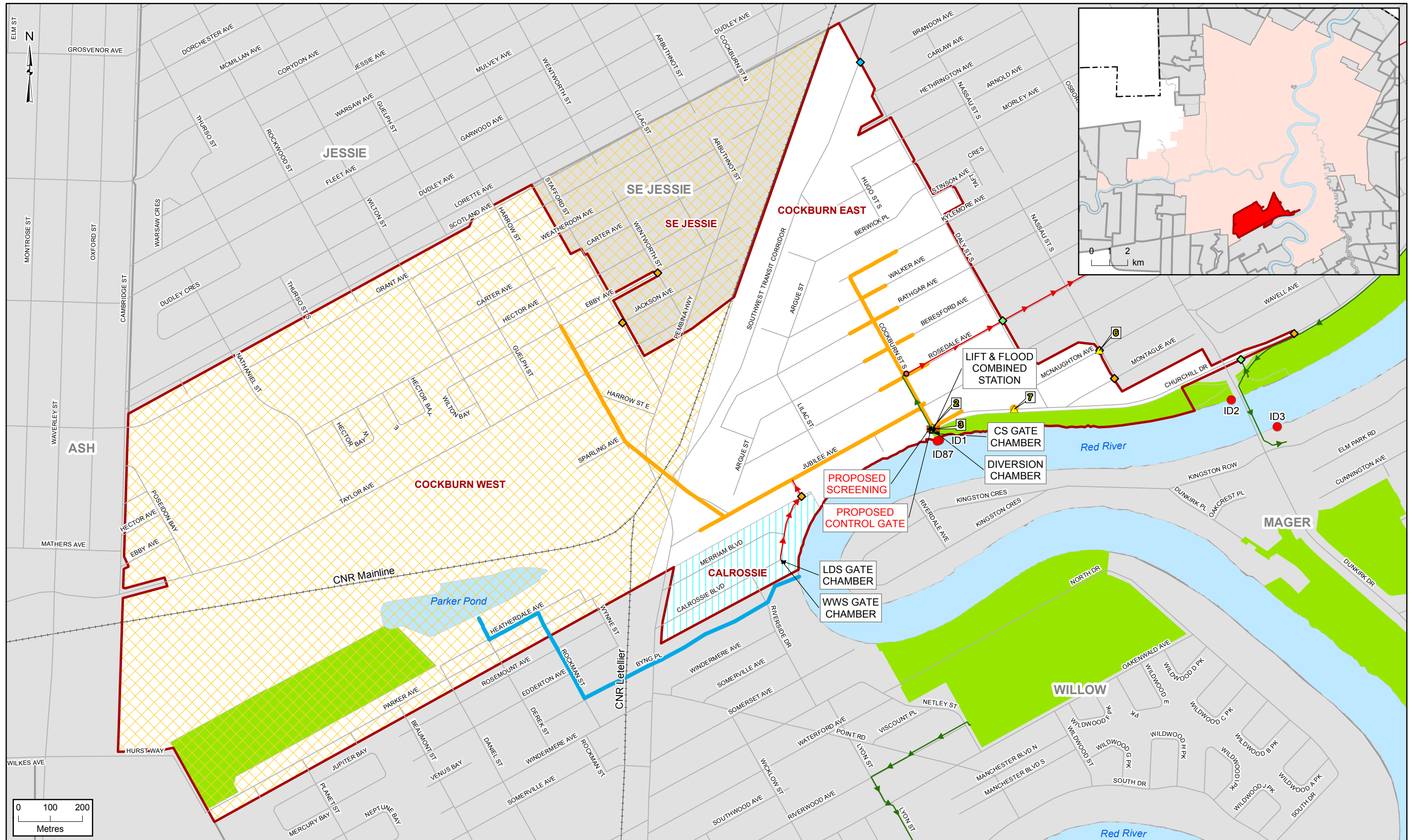

LEGEND

CSO MASTER PLAN PROPOSED SOLUTIONS

ALL PROPOSED SOLUTIONS SHOWN IN RED TEXT



Notes:
1. Map data source - City of Winnipeg, 2013

FIGURE 09
District Overview Map
Sewer District: Cockburn
City of Winnipeg
Combined Sewer Overflow Master Plan



LEGEND

- | | | | | |
|--|--|--|-------------------------------|--------------------------|
| | | | Control Structure Type | Pump Station Type |
| | | | | |
| | | | | |
| | | | | |
| | | | | |

**CSO MASTER PLAN
PROPOSED SOLUTIONS**

- Control Gate
- Screening

**ALL PROPOSED SOLUTIONS
SHOWN IN RED TEXT**



Notes:
1. Map data source - City of Winnipeg, 2013

**FIGURE 09-01
Control Gate and Screening
Sewer District: Cockburn
City of Winnipeg
Combined Sewer Overflow Master Plan**